



Carroll County Department of Fire & EMS

Standard Operating Procedure: 1.13	Effective Date: 5/1/2024
Subject: Uniform Policy	Section: Administration
Authorized: Chief Michael W. Robinson/MWR	Revision Date: 2/5/2025

I. PURPOSE

The Carroll County Department of Fire and EMS (DFEMS) shall provide all career personnel with the equipment and uniform components necessary to perform their duties. DFEMS uniforms identifies members of the organization, ensures a measure of uniformity, and promotes professionalism. Employees are responsible for the proper care and maintenance of all issued equipment and uniforms. Supervisors are responsible for inspecting employees to ensure equipment and uniforms are kept in good working order. This policy establishes a procedure for the issuance, replacement, use, and composition for career employee's uniforms.

II. DEFINITIONS

Uniform - Issued or authorized clothing articles and accessories to be worn by members when on duty and as specified for various levels of work.

Class A Uniform - The dress uniform consisting of an issued blouse coat, dress pants, dress hat, and related devices/insignia to be worn at specific fire department or public events.

Class B Uniform – The official work uniform typically worn by staff officers and can be worn by field personnel.

Class C Uniform – Fatigue Uniform that is the minimum required for field personnel. This may include polo, t-shirt, or summer configurations.

Class D Uniform - Athletic attire utilized for physical training or while utilizing dormitory areas.

III. PROCEDURES

A. General

1. The department shall be responsible for obtaining and issuance of career employee uniforms. This excludes uniforms for reasons such as special events listed below.
2. Specification of the uniform shall be approved by the Fire EMS Chief.
3. The Fire EMS Chief shall have the authority to make changes to the uniform standard whenever deemed appropriate. Such cases may include, but not limited to:
 - a. Special events such as Breast Cancer Awareness, Autism Awareness, etc.
 - b. Fiscal restrictions.
 - c. Safety driven changes.
 - d. Significant weather event.
4. The Fire EMS Chief may authorize the individual procurement of optional uniform items not issued by DFEMS.
5. Appropriate cleaning and maintenance shall be the responsibility of the employee.
6. All career employees shall secure uniforms to prevent loss from damage or theft.
7. Employees of DFEMS who, through malice, negligence, or carelessness, damages' or loses any DFEMS property may be required to reimburse DFEMS for the cost of replacing the property.

B. Issuance of Uniforms

1. Upon appointment to the department, personnel shall receive the initial issued uniform items.
2. Personnel may be issued additional items based on assignment or promotion.
3. Personnel shall sign and acknowledge receipt of uniforms.
4. Uniforms may be requested to be returned upon separation of employment.
5. Uniform Footwear shall be black shoes or boots in accordance with Risk Management Policy and Procedure: Foot Protection Program.
6. Class A Uniforms are eligible to be issued to uniformed employees upon completion of the probationary period or otherwise designated by the Fire EMS Chief.

C. Uniform Replacement Request:

1. Uniforms will be replaced on a one-for-one, as-needed basis.
2. Station Officers and Shift Commanders shall monitor personnel uniform requests.
3. Station Officer or Shift Commander shall reserve the right to inspect any uniform item prior to authorizing a replacement.

4. Employees shall complete a Loss/Damage Report and submit it, along with the uniform item to be replaced, to their assigned supervisor for a replacement uniform item.
5. All requests need to be evaluated and pre-approved by the employee's supervisor prior to being issued a replacement uniform item.
6. The employee shall sign the uniform request form acknowledging receipt of the uniform item.
7. Lost or stolen uniforms
 - a. Documentation shall be completed by the employee for any uniform item that is unaccounted for prior to replacement.
 - b. Supervisor shall sign the Loss/Damage Report and complete an investigation into the incident.
 - c. If the item was lost or stolen due to negligence the employee may be required to purchase the replacement uniform item.
 - d. Any uniform item to include badges, identification cards, or items over \$150.00 in value must be reported to the Carroll County Sheriff's office for an official report to be taken for a stolen uniform item.
 - e. Uniform items that are essential to perform job duties can be replaced through an emergency request and the Training, Safety and Health Chief can authorize the Shift Commander to issue the uniform item in the absence of the Quarter Master.

D. Wear Requirements

1. The wearing of uniform items is authorized:
 - a. When on duty.
 - b. Approved department functions.
 - c. Attending department sanctioned classes.
 - d. Any other time approved by the Fire EMS Chief.
2. Personnel shall not wear any part of the uniform in a manner that would bring disrepute upon the department while in the public's eye. This includes but not limited to:
 - a. Wearing a Class B button up shirt not tucked into trousers.
 - b. Wearing a baseball style hat backwards.
 - c. Wearing authorized protective footwear untied or unzipped.
 - d. Wearing trousers tucked into protective footwear.
3. Uniformed employees on modified duty may wear other appropriate clothing as a necessary accommodation with the approval of the supervisor.
4. Shift Commander may authorize their employees to wear uniform articles or additional clothing items suitable for the task at hand or extreme weather conditions.
5. Uniformed employees shall wear only the uniform items issued or authorized by the Fire EMS Chief.
6. Uniformed employees shall wear a Class B uniform when attending administrative meetings or details involving the public, i.e., inter-departmental meetings, disciplinary hearings, fire prevention, public relations, etc.

E. Uniform for Daily Operations of Field Personnel

1. Daily uniform shall consist of Class B or Class C with polo.
2. Alterations to the daily uniform can be made by the Shift Commander and communicated to members.
3. Wearing of a Class D uniform is authorized while members are actively involved in fire or physical training. At no time shall the Class D uniform be worn during incident response.
4. Class C uniforms with department issued tee shirts are authorized while on duty after 17:00 daily.
5. Any other deviation from the Daily Uniform shall require authorization by the Shift Commander.
6. All uniformed personnel are required to have their Class B uniform accessible while on-duty in case operations or the occasion requires it.

F. Types of Uniforms

1. Class A Uniform
 - a. Considered the department's full-dress uniform and shall be worn when members attend departmental funerals, awards presentations, graduation ceremonies, or special occasions authorized by the Fire EMS Chief or his designee. Class A Uniforms are issued to uniformed employees upon completion of the probationary period.
 - b. Class A uniform consist of the following items:
 - i. Navy blue uniform 4-pocket, single-breasted coat.
 1. Ranks up to Lieutenant wear silver buttons.
 2. Ranks from Captain and above wear gold buttons.
 - ii. Department patch is positioned on the left sleeve at the shoulder.
 - iii. Individual volunteer companies shall wear company patch on left sleeve at the shoulder.
 - iv. Maryland EMS certification or other patch approved by the Fire EMS Chief shall be worn on the right sleeve position at the shoulder.
 - v. Sleeve stripes are worn 2.5 inches above the cuff according to rank.
 1. Lieutenants wear a single silver stripe.
 2. Captains and above wear gold striping.
 - a. 2 stripes – Captain
 - b. 3 stripes – Assistant Chief
 - c. 4 stripes – Deputy Chief
 - d. 5 stripes – Fire EMS Chief
 - c. Navy blue dress trousers (Females may substitute an approved uniform skirt).
 - d. White or dark-navy long-sleeve dress uniform shirt (appropriate for rank).

- i. All personnel at or above the rank of Lieutenant shall wear White dress uniform shirt.
 - e. Black necktie with tie tack or bar matching brass color.
 - f. Plain white t-shirt style under shirt. Under shirts with writing, screen printing or any other marking that can be seen through the dress shirt are prohibited.
 - g. Badge, Name plate, collar pins, and lapel insignia. In all cases a name plate shall be worn centered on the flap of the right breast pocket. The bottom edge on the nameplate shall be worn even with the top of the seam flap.
 - h. Service wreath pins, union pins and/or award ribbons are optional.
 - i. Service wreath pins are worn on the right sleeve, 2.5” above the cuff or last stripe.
 - ii. Award ribbons are worn centered, 1/8” above the nameplate in rows of 3. Ribbons shall be worn in order, according to the Order of Precedence identified in the SOP regarding Commendations. Multiple ribbons will be worn utilizing a ribbon rack appropriate for the number of ribbons obtained.
 - iii. See Attachment B for appropriate Class A coat configuration.
 - i. Dress Socks – Black
 - j. Dress hat with badge, dress hat shall be worn at all times when outside.
 - i. Silver band worn for Lieutenant
 - ii. Gold band worn for Captain and above.
 - k. Black belt with silver or gold buckle depending upon rank.
 - i. See Attachment C for optional belt buckle.
 - l. Black shoes shall have a plain toe with clean, high gloss finish and not have an ornamental design. Dress shoes shall be tied at all times.
 - m. Optional all-weather raincoat/overcoat may be worn.
 - n. The DFEMS Honor Guard will wear a Class A configuration in accordance with the Honor Guard SOP.
- 2. Class B Uniform
 - a. The Class B uniform is considered a semi-dress uniform that consists of staff and fatigue versions.
 - b. Staff version shall include:
 - i. Winter- long sleeve Class B shirt (color based on rank), tie, all issued insignia.
 - ii. Summer- Short sleeve Class B shirt (color based on rank), all issued insignia.
 - iii. Lieutenants and above wear a white Class B uniform shirt while not operationally on-duty. (i.e. attending meetings, events, etc.)
 - iv. Ribbons and other devices beyond basically issued insignia are optional on the staff-version of the Class B.

- c. Fatigue version shall include: a navy fatigue uniform shirt, all issued insignia.
 - i. Ribbons and other devices are not worn on the fatigue version of the Class B uniform, unless otherwise instructed.
 - d. Fatigue version shall be worn by field operation personnel while operationally on-duty in the following situations unless otherwise directed by an officer of DFEMS:
 - i. Field operations (if not wearing Class C with polo.)
 - ii. Details involving the public, such as fire prevention, inspections, community events, etc.
 - iii. Meetings involving entities outside of DFEMS.
 - iv. Administrative hearings.
 - v. Other times as directed by an officer of DFEMS.
 - e. Class B uniform consists of the following items:
 - i. Navy blue staff trousers or navy-blue duty trousers based on assignment.
 - ii. Navy fatigue/white long or short sleeve uniform shirt.
 - iii. Badge, Name plate, collar insignia.
 - 1. Ranks up to Lieutenant wear silver.
 - 2. Ranks from Captain and above wear gold.
 - iv. Union Pins and other approved pins are optional.
 - v. Department issued black belt.
 - 1. See Attachment C for optional belt buckle.
 - vi. Department authorized black shoes or boots.
 - vii. Department issued baseball-style cap.
 - viii. Other department issued apparel may be worn with the Class B uniform if approved by the Shift Commander.
 - ix. See Attachment D for the List of Approved Optional Uniform Items.
3. Class C Uniform
- a. Navy blue duty trousers.
 - b. Department issued tee shirt.
 - c. Employee provided/approved polo shirt.
 - i. See Attachment D for authorized polo for on-duty wear to be purchased through approved vendors at employee expense. Embroidered according to Attachment F.
 - 1. DFEMS logo/maltese embroidered on left chest.
 - 2. Rank and Last Name embroidered on right chest.
 - a. FF, PM, FF/PM, FADO – red lettering.
 - b. Lieutenant – silver lettering.
 - c. Captain and above – gold lettering.
 - d. Department authorized black safety shoes or boots.
 - e. Navy blue or black socks.
 - f. Department issued belt.
 - g. Other departmental issued items:
 - i. Job shirt.
 - ii. Reflective outer jacket.
 - iii. Winter watch cap.

- iv. Baseball-style cap.
- v. Quilted Jacket.
- h. Optional employee provided items:
 - i. Uniform belt with custom buckle
 - 1. See Attachment C for authorized style.
 - ii. See Attachment D for the List of Approved Optional Uniform Items.
- 4. Class D Uniform
 - a. This uniform is a physical training uniform and shall only be worn during physical training activities or retiring to the dormitory. Class D uniform shall not be worn during incidents.
 - b. Class D uniform consist of the following:
 - i. Department issued navy blue long or short sleeve tee shirt.
 - ii. Navy blue shorts*.
 - iii. Navy blue sweatpants*.
 - iv. Athletic shoes*.

*Employee provided

G. Separation of Employment

1. All uniform items shall remain property of the department.
2. All uniform items are required to be returned to the department at separation of employment.
3. Retired employees shall maintain a Class A uniform to participate in formal departmental activities.
4. DFEMS employees shall be required to turn over to their commanding officer their badges and identification cards while under suspension or investigation that may lead to separation of employment.

H. Optional Uniform Items

1. The procurement of optional uniforms shall be solely at the employee's discretion.
2. Only DFEMS approved vendors shall be used to obtain optional uniform items.
3. A list of optional vendors will be maintained by the Administrative Assistant assigned to the Fire EMS Chief and is available upon request.
4. Optional uniform items shall be considered official uniform components.
 - a. See Attachment D for a list of approved optional uniform items.
 - b. See Attachment E for the process to propose additional optional uniform items.

I. Misuse of the Uniform

1. No employee of DFEMS shall, for any reason, allow any other person to use the employee's badge or other uniform insignia or device, and part of the employee's uniform, or the employee's identification.
2. Employees of DFEMS shall not sell, lend, exchange, pledge, or otherwise encumber or improperly dispose of their uniform or any part thereof, or any article of Department property.

IV. RECISION

This Standard Operating Procedure rescinds all directives regarding Uniforms or similar content previously issued for personnel of the Carroll County Department of Fire & EMS Department.

V. RELATED STANDARD OPERATING PROCEDURES

- A. SOP #TBD: Commendations Board
- B. SOP #TBD: Honor Guard

VI. ATTACHMENTS:

- A. How to Wear Your Brass
- B. Class A Coat Configuration
- C. Approved Uniform Belt with Custom Buckle
- D. List of Authorized Uniform Items
- E. Submitting Optional Uniform Items for Authorization
- F. DFEMS Embroidery Guidelines

ATTACHMENT A

How to Wear Your Class B Brass

Badge:

Badges are to be worn on the left chest. The pin back of the badge goes through the 2 pre-set holes above the pocket.

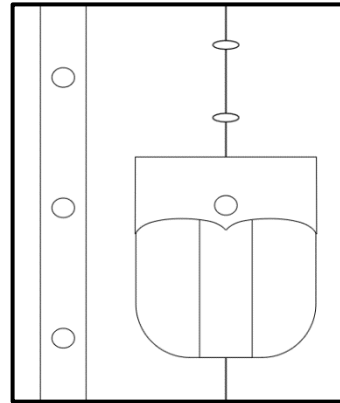

Collar Pins (Insignia):

Center the insignia $\frac{1}{4}$ inch from the front and lower edges of the collar. Position the vertical axis of the insignia along the imaginary line bisecting the angle of the collar point.

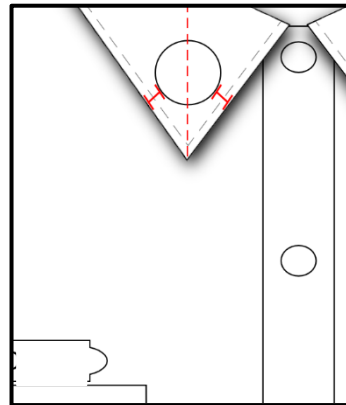

Name Plate:

Worn on the right chest above the pocket. Center the name plate on the pocket with the bottom of the name plate along the top edge of the pocket.

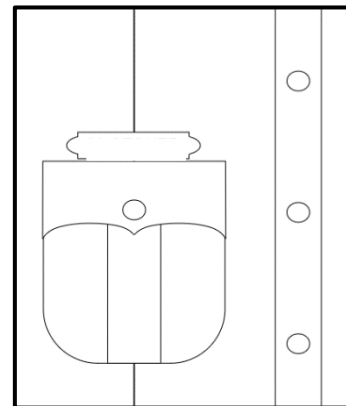

Attachment B Class A Coat Configuration



Attachment C

Approved Uniform Belt with Custom Buckle

Irvin Hahn Belt Buckle B-4005 with 1 ½" black Garrison Belt

Finish – Silver for Lieutenant and below.

Gold for Captain and above.

"CARROLL COUNTY" on the top line.

Appropriate Center Seal.

"DFEMS" or First Initial, Last Name on the bottom line.



Attachment D

List of Authorized Uniform Items

Below is the list of authorized uniform items, including employee purchased optional items. Quartermaster is able to make changes as necessary to department issued apparel.

Class A, B, and C Uniforms as specified by SOP 1.13.

Job Shirts:

Game Quarter Zip Job Shirt	
Color: Navy	Style #: 811
5.11 Job Shirt ¼ Zip 2.0	
Color: Fire Navy	Style #: 72534
Carhartt Rain Defender Heavyweight Quarter Zip Hoodie*	
Color: New Navy	Style #: 100617

Jackets:

Game “The Bravest” Diamond Quilted Jacket	
Color: Navy	
Elbeco Shield Hi-Vis Reversible Soft Shell Jacket	
Color: HiVis/Navy	Elbeco SKU #: SH3724RV

Authorized Polos:*

UnderArmour Tactical Performance Polo 2.0 - Long or Short Sleeve	
Color: Dark Navy	
5.11 Helios Short Sleeve Polo	
Color: Dark Navy	Style #: 41192
Cornerstone Select Snag-Proof Polo	
Color: Navy	Style #: CS412

Navy Blue Uniform T-Shirts:

50/50 Cotton/Poly T-Shirt	
3.5” screen printed white outline of DFEMS Maltese Cross on left chest.	
Screen printed approved design on shirt back.	

Hats:

Navy Blue Adjustable Baseball-Style Cap	
Navy Blue FlexFit Baseball-Style Cap*	
Baseball-Style Caps are to be embroidered with 2.5” DFEMS Maltese	
Navy Blue Knit Cap	
Embroidered with “DFEMS” - white outline; red inside	

Navy Blue Athletic Shorts and Sweatpants:*

<u>Only for use with Class D Uniform</u>	
Optional - Screen printed white outline of DFEMS Patch on left thigh.	

Attachment E

Submitting Optional Uniform Items for Authorization

To submit proposed Optional Uniform Items for authorization by the Fire EMS Chief for on-duty wear, DFEMS uniformed personnel must:

1. Ensure uniform is widely available and is not contradictory to general DFEMS uniform expectations already in practice.
2. Submit proposal and pictures of the proposed optional uniform item to immediate supervisor for approval up the DFEMS chain of command.
 - Proposals must be completed on DFEMS memo and include specific information on make, model, material, expected pricing and availability.
3. Once submitted to the Fire EMS Chief through appropriate channels, the Fire EMS Chief will decide on the proposed optional uniform item.
4. If the proposed optional uniform item is approved by the Fire EMS Chief, it will be sent to the approved vendors to be made available for purchase and added to SOP 1.13 Attachment D – List of Authorized Optional Uniform Items.

NOTE: Proposed Optional Uniform Items are not to be worn until approved by the Fire EMS Chief in writing. Only items approved by the Fire EMS Chief for testing can be worn prior to final approval.

Attachment F

DFEMS Embroidery Guidelines

Vendors approved by Carroll County Government/Department of Fire & EMS are to use the following specifications for embroidery of approved departmental apparel. ONLY items approved per DFEMS SOP 1.13-Attachment D are authorized for employee purchase and for on-duty wear by personnel.

Embroidery for Job Shirts, Jackets, and Polo Shirts:

Left Chest - 3.5" x 3.5" CCDFEMS Logo

Madeira Polyneon Thread Colors

Red - 1781 Radish

Navy - 1643 Navy

Yellow (MD Flag) - 1971 Saffron

Black - 1800 Emerald Black

Gold - 1939 Peanut Brittle

White - 1801 Super White

Horse/Wagon - 1927 Shiny Penny



NOTE: Embroidery Logo *is not* the same as the normally used DFEMS Patch or Maltese Logo. .SVG file of logo available upon request by vendor.

Right Chest - Rank and Name

Font: Times New Roman

Size: ½"

Line 1 - Rank

Firefighter/EMT

FADO

Paramedic

Firefighter/Medic

Lieutenant

Captain

Assistant Chief

Deputy Chief

Fire EMS Chief

Line 2 - First Initial, Last Name

Example:

Fire EMS Chief

M. Robinson

Color:

Red - 1781 Radish -

Firefighter/EMT, FADO, Paramedic,
Firefighter/Medic

Silver - 1812 Cement -

Lieutenant

Gold - 1939 Peanut Brittle -

Captain, Assistant Chief, Deputy Chief,
Fire EMS Chief

Embroidery for Hats:

Baseball-Style Caps - 2.5" x 2.5" embroidered DFEMS maltese cross (same as above).

Knit Caps - DFEMS embroidered above bottom edge - white border, red interior